

Hongli Zhihui Group Co.,Ltd. Guangzhou Branch
Room 316, Building 2, No.1, Xianke Yi Road, Huadong Town, Huadu District, Guangzhou, China

#Model: HL-AS-3528HW-3C-S1-08L-
PCT-HR5

Report Type: 6000 Hours Test Report	Product Type: LED Package
Test Engineer :	Pote Wang 
Report Number:	RSZ190926502-10-6000
Test Date:	2019-09-29 to 2020-07-02
Report Date:	2020-07-16
Reviewed By:	Bill Xiong / EE Engineer
Test Facility :	Test facility was located at No.69,Pulongcun ,Puxinhu Industrial Area, Tangxia , Dongguan, Guangdong, China.
Prepared By:	Bay Area Compliance Laboratories Corp. (Dongguan). No.69,Pulongcun ,Puxinhu Industrial Area, Tangxia , Dongguan, Guangdong, China. Tel: +86-0769-86858888 Fax:+86-0769-86858588
Accreditation :	The IAS Accreditation Number TL-460.

TABLE OF CONTENTS

1 -	General Information	3
1.1	Description of LED Light Sources	3
1.2	Standards and Reference Documentations	14
1.3	Testing Equipment	14
1.4	Drive Level	15
1.5	Ambient Conditions for Maintenance Test	15
1.6	Photometric Measurement Method and Uncertainty	15
1.7	Statement of Traceability	15
1.8	Sample Set	15
2 -		16
3 -		17
3.1	Data Set 1, 85°C, 100mA (Lumen Maintenance)	17
3.2	Data Set 1, 85°C, 100mA (Forward Voltage)	18
3.3	Data Set 1, 85°C, 100mA (Chromaticity Shift)	19
3.4	Data Set 2, 105°C, 100mA (Lumen Maintenance)	20
3.5	Data Set 2, 105°C, 100mA (Lumen Maintenance)	20
		23
4.1	Mechanical Dimensions	23
4.2		

1 - General Information

1.1 Description of LED Light Sources

Sample Size:

60 PCS test samples were in good condition and received on 2019-09-26. The samples were numbered from 1 to 30 and 31 to 60.

#Manufacturer:	Hongli Zhihui Group Co.,Ltd. Guangzhou Branch
#Part Number:	HL-AS-3528HW-3C-S1-08L-PCT-HR5
#Part Type:	LED Package
#Drive Level:	DC 100mA
#Nominal CCT:	2700K
#Power:	1.04W
#Average Current Density per LED die:	575mA/mm ²
#Average Power Density per LED die:	1.990W/mm ²
#CRI:	90
#Die Spacing:	0.15mm

Sampling Method :

LED samples for IESNA LM-80 testing consist of units built from a minimum of three manufacturing lots with each manufacturing lot built from different wafer lots built on non-consecutive days.

These manufacturing lots are picked to represent a wide parametric distribution.

#Family products covered by this report:

According to *ENERGY STAR® Requirements for the Use of LM-80 Data*, the following products can be covered by this report base on the information and declaration provided by manufacturer. The information of these models shows that the covered products meet all section 4 requirements of *ENERGY STAR® Requirements for the Use of LM-80 Data* (September 28, 2017)

This report covers the following models:

Model name	CRI (typ.)	CCT (typ.)	Series	Parallel	Power density (W/mm ²)	Current density per LED die (mA/mm ²)	Current per die (mA)	Distance between of dies	Current (mA)
HL-AS-3528HW-3C-S1-08L-PCT-HR5	90	2700K	3	1	0.1061	575	100	0.15	100
HL-AS-3528H***W-3C-S1-08L-PCT-HR5	90	3000K	3	1	0.1061	575	100	0.15	100
	90	4000K	3	1	0.1061	575	100	0.15	100
	90	5000K	3	1	0.1061	575	100	0.15	100
	90	5700K	3	1	0.1061	575	100	0.15	100
	90	6500K	3	1	0.1061	575	100	0.15	100
	90		3	1	0.1061	575	100	0.15	100
HL-AS-3528H***W-3C-S1-08L-PCT-HR5(R9)	90	2700K	3	1	0.1061	575	100	0.15	100
	90	3000K	3	1	0.1061	575	100	0.15	100
	90	4000K	3	1	0.1061	575	100	0.15	100
	90	5000K	3	1	0.1061	575	100	0.15	100
	90	5700K	3	1	0.1061	575	100	0.15	100
	90	6500K	3	1	0.1061	575	100	0.15	100
	90		3	1	0.1061	575	100	0.15	100

HL-AS-3528H***W-3C-S1-08-PCT-HR5	90	2700K	3	1	0.1061	575	100	0.15	100
	90	3000K	3	1	0.1061	575	100	0.15	100
	90	4000K	3	1	0.1061	575	100	0.15	100
	90	5000K	3	1	0.1061	575	100	0.15	100
	90	5700K	3	1	0.1061	575	100	0.15	100
	90	6500K	3	1	0.1061	575	100	0.15	100
	90		3	1	0.1061	575	100	0.15	100
HL-AS-3528H***W-3C-S1-08-PCT-HR5(R9)	90	2700K	3	1	0.1061	575	100	0.15	100
	90	3000K	3	1	0.1061	575	100	0.15	100
	90	4000K	3	1	0.1061	575	100	0.15	100
	90	5000K	3	1	0.1061	575	100	0.15	100
	90	5700K	3	1	0.1061	575	100	0.15	100
	90	6500K	3	1	0.1061	575	100	0.15	100
	90		3	1	0.1061	575	100	0.15	100
HL-AS-3528D***W-3C-S1-08L-PCT-HR5	90	2700K	3	1	0.1061	517	100	0.15	100
	90	3000K	3	1	0.1061	517	100	0.15	100
	90	4000K	3	1	0.1061	517	100	0.15	100
	90	5000K	3	1	0.1061	517	100	0.15	100
	90	5700K	3	1	0.1061	517	100	0.15	100
	90	6500K	3	1	0.1061	517	100	0.15	100
	90		3	1	0.1061	517	100	0.15	100
HL-AS-3528D***W-3C-S1-08L-PCT-HR5(R9)	90	2700K	3	1	0.1061	517	100	0.15	100
	90	3000K	3	1	0.1061	517	100	0.15	100
	90	4000K	3	1	0.1061	517	100	0.15	100
	90	5000K	3	1	0.1061	517	100	0.15	100
	90	5700K	3	1	0.1061	517	100	0.15	100

HL-AS-3528H***W-2C-S1-08L-PCT-HR5	90	2700K	2	1	0.1041	554	150	0.15	150
	90	3000K	2	1	0.1041	554	150	0.15	150
	90	4000K	2	1	0.1041	554	150	0.15	150
	90	5000K	2	1	0.1041	554	150	0.15	150
	90	5700K	2	1	0.1041	554	150	0.15	150
	90	6500K	2	1	0.1041	554	150	0.15	150
	90		2	1	0.1041	554	150	0.15	150
HL-AS-3528H***W-2C-S1-08L-PCT-HR5(R9)	90	2700K	2	1	0.1041	554	150	0.15	150
	90	3000K	2	1	0.1041	554	150	0.15	150
	90	4000K	2	1	0.1041	554	150	0.15	150
	90	5000K	2	1	0.1041	554	150	0.15	150
	90	5700K	2	1	0.1041	554	150	0.15	150
	90	6500K	2	1	0.1041	554	150	0.15	150
	90		2	1	0.1041	554	150	0.15	150
HL-AS-3528H***W-2C-S1-08-PCT-HR5	90	2700K	2	1	0.1041	554	150	0.15	150
	90	3000K	2	1	0.1041	554	150	0.15	150
	90	4000K	2	1	0.1041	554	150	0.15	150
	90	5000K	2	1	0.1041	554	150	0.15	150
	90	5700K	2	1	0.1041	554	150	0.15	150
	90	6500K	2	1	0.1041	554	150	0.15	150
	90		2	1	0.1041	554	150	0.15	150
HL-AS-3528H***W-2C-S1-08-PCT-HR5(R9)	90	2700K	2	1	0.1041	554	150	0.15	150
	90	3000K	2	1	0.1041	554	150	0.15	150
	90	4000K	2	1	0.1041	554	150	0.15	150
	90	5000K	2	1	0.1041	554	150	0.15	150
	90	5700K	2	1	0.1041	554	150	0.15	150
	90	6500K	2	1	0.1041	554	150	0.15	150
	90		2	1	0.1041	554	150	0.15	150
HL-AS-3528D***W-2C-S1-08L-PCT-HR5	90	2700K	2	1	0.1041	554	150	0.15	150
	90	3000K	2	1	0.1041	554	150	0.15	150
	90	4000K	2	1	0.1041	554	150	0.15	150
	90	5000K	2	1	0.1041	554	150	0.15	150
	90	5700K	2	1	0.1041	554	150	0.15	150
	90	6500K	2	1	0.1041	554	150	0.15	150
	90		2	1	0.1041	554	150	0.15	150
HL-AS-3528D***W-2C-S1-08L-PCT-HR5(R9)	90	2700K	2	1	0.1041	554	150	0.15	150
	90	3000K	2	1	0.1041	554	150	0.15	150
	90	4000K	2	1	0.1041	554	150	0.15	150
	90	5000K	2	1	0.1041	554	150	0.15	150
	90	5700K	2	1	0.1041	554	150	0.15	150
	90	6500K	2	1	0.1041	554	150	0.15	150
	90		2	1	0.1041	554	150	0.15	150

HL-AS-3528D***W-2C-S1-08-PCT-HR5	90	2700K	2	1	0.1041	554	150	0.15	150
	90	3000K	2	1	0.1041	554	150	0.15	150
	90	4000K	2	1	0.1041	554	150	0.15	150
	90	5000K	2	1	0.1041	554	150	0.15	150
	90	5700K	2	1	0.1041	554	150	0.15	150
	90	6500K	2	1	0.1041	554	150	0.15	150
	90		2	1	0.1041	554	150	0.15	150
HL-AS-3528D***W-2C-S1-08-PCT-HR5(R9)	90	2700K	2	1	0.1041	554	150	0.15	150
	90	3000K	2	1	0.1041	554	150	0.15	150
	90	4000K	2	1	0.1041	554	150	0.15	150
	90	5000K	2	1	0.1041	554	150	0.15	150
	90	5700K	2	1	0.1041	554	150	0.15	150
	90	6500K	2	1	0.1041	554	150	0.15	150
	90		2	1	0.1041	554	150	0.15	150
HL-AS-3528H***W-S1-08L-PCT-HR5	90	2700K	1	1	0.0209	345	60	/	60
	90	3000K	1	1	0.0209	345	60	/	60
	90	4000K	1	1	0.0209	345	60	/	60
	90	5000K	1	1	0.0209	345	60	/	60
	90	5700K	1	1	0.0209	345	60	/	60
	90	6500K	1	1	0.0209	345	60	/	60
	90		1	1	0.0209	345	60	/	60
HL-AS-3528H***W-S1-08L-PCT-HR5(R9)	90	2700K	1	1	0.0209	345	60	/	60
	90	3000K	1	1	0.0209	345	60	/	60
	90	4000K	1	1	0.0209	345	60	/	60
	90	5000K	1	1	0.0209	345	60	/	60
	90	5700K	1	1	0.0209	345	60	/	60
	90	6500K	1	1	0.0209	345	60	/	60
	90		1	1	0.0209	345	60	/	60
HL-AS-3528H***W-S1-08-PCT-HR5	90	2700K	1	1	0.0209	345	60	/	60
	90	3000K	1	1	0.0209	345	60	/	60
	90	4000K	1	1	0.0209	345	60	/	60
	90	5000K	1	1	0.0209	345	60	/	60
	90	5700K	1	1	0.0209	345	60	/	60
	90	6500K	1	1	0.0209	345	60	/	60

HL-AS-3528D***W-S1-08L-PCT-HR5	90	2700K	1	1	0.0521	554	150	/	150
	90	3000K	1	1	0.0521	554	150	/	150
	90	4000K	1	1	0.0521	554	150	/	150
	90	5000K	1	1	0.0521	554	150	/	150
	90	5700K	1	1	0.0521	554	150	/	150
	90	6500K	1	1	0.0521	554	150	/	150
	90		1	1	0.0521	554	150	/	150
HL-AS-3528D***W-S1-08L-PCT-HR5(R9)	90	2700K	1	1	0.0521	554	150	/	150
	90	3000K	1	1	0.0521	554	150	/	150
	90	4000K	1	1	0.0521	554	150	/	150
	90	5000K	1	1	0.0521	554	150	/	150
	90	5700K	1	1	0.0521	554	150	/	150
	90	6500K	1	1	0.0521	554	150	/	150
	90		1	1	0.0521	554	150	/	150
HL-AS-3528D***W-S1-08L-PCT-HR5	90	2700K	1	1	0.0521	554	150	/	150
	90	3000K	1	1	0.0521	554	150	/	150
	90	4000K	1	1	0.0521	554	150	/	150
	90	5000K	1	1	0.0521	554	150	/	150
	90	5700K	1	1	0.0521	554	150	/	150
	90	6500K	1	1	0.0521	554	150	/	150
	90		1	1	0.0521	554	150	/	150
HL-AS-3528D***W-S1-08L-PCT-HR5(R9)	90	2700K	1	1	0.0521	554	150	/	150
	90	3000K	1	1	0.0521	554	150	/	150
	90	4000K	1	1	0.0521	554	150	/	150
	90	5000K	1	1	0.0521	554	150	/	150
	90	5700K	1	1	0.0521	554	150	/	150
	90	6500K	1	1	0.0521	554	150	/	150
	90		1	1	0.0521	554	150	/	150
HL-AS-3528H***W-S1-2-08L-PCT-HR5	90	2700K	1	2	0.0521	554	75	0.15	150
	90	3000K	1	2	0.0521	554	75	0.15	150
	90	4000K	1	2	0.0521	554	75	0.15	150
	90	5000K	1	2	0.0521	554	75	0.15	150
	90	5700K	1	2	0.0521	554	75	0.15	150
	90	6500K	1	2	0.0521	554	75	0.15	150
	90		1	2	0.0521	554	75	0.15	150
HL-AS-3528H***W-S1-2-08L-PCT-HR5(R9)	90	2700K	1	2	0.0521	554	75	0.15	150
	90	3000K	1	2	0.0521	554	75	0.15	150
	90	4000K	1	2	0.0521	554	75	0.15	150
	90	5000K	1	2	0.0521	554	75	0.15	150
	90	5700K	1	2	0.0521	554	75	0.15	150
	90	6500K	1	2	0.0521	554	75	0.15	150
	90		1	2	0.0521	554	75	0.15	150

HL-AS-3528H***W-S1-2-08-PCT-HR5	90	2700K	1	2	0.0521	554	75	0.15	150
	90	3000K	1	2	0.0521	554	75	0.15	150
	90	4000K	1	2	0.0521	554	75	0.15	150
	90	5000K	1	2	0.0521	554	75	0.15	150
	90	5700K	1	2	0.0521	554	75	0.15	150
	90	6500K	1	2	0.0521	554	75	0.15	150
	90		1	2	0.0521	554	75	0.15	150
HL-AS-3528H***W-S1-2-08-PCT-HR5(R9)	90	2700K	1	2	0.0521	554	75	0.15	150
	90	3000K	1	2	0.0521	554	75	0.15	150
	90	4000K	1	2	0.0521	554	75	0.15	150
	90	5000K	1	2	0.0521	554	75	0.15	150
	90	5700K	1	2	0.0521	554 ^{351.2 518.353}	75	0.15	150
	90	6500K	35	68					

FINAL



Bay Area Compliance Laboratories Corp. (Dongguan)

No.69, Puolongun, Puxinhu Industrial Area, Dongguan, Guangdong, China
The IAS Accreditation Number: L-460

FINAL

FINAL

FINAL

HL-A-3528D***W-S1-2-08-PCT-HR5	90	2700K	1	2	0.0521	554	75	0.15	150
	90	3000K	1	2	0.0521	554	75	0.15	150
	90	4000K	1	2	0.0521	554	75	0.15	150
	90	5000K	1	2	0.0521	554	75	0.15	150
	90	5700K	1	2	0.0521	554	75	0.15	150
	90	6500K	1	2	0.0521	554	75	0.15	150
	90		1	2	0.0521	554	75	0.15	150
HL-A-3528D***W-S1-2-08-PCT-HR5(R9)	90	2700K	1	2	0.0521	554	75	0.15	150
	90	3000K	1	2	0.0521	554	75	0.15	150
	90	4000K	1	2	0.0521	554	75	0.15	150
	90	5000K	1	2	0.0521	554	75	0.15	150
	90	5700K	1	2	0.0521	554	75	0.15	150
	90	6500K	1	2	0.0521	554	75	0.15	150
	90		1	2	0.0521	554	75	0.15	150

The family models and tested model could meet all the requirements listed as below:

- The testes model has the greatest number of LED dies. and,
- Minimum die edge of die edge spacing of the family models is greater than or equal to that of the tested LED package; and,
- the family models equal to the tested LED package; and,
- average current density per LED die (i.e. mA/mm² of epitaxial structures) less than or equal to the tested LED package; and,
- identical materials used (note: this does not constrain phosphor quantity and/or dimensional adjustments); and,
- identical construction processes used;
- d for the brightness level.

1.2 Standards and Reference Documentations

ANSI/IES LM-80-15: IES Approved Method for Measuring Lumen Maintenance of LED Light Sources.
CIE 127:2007: Measurement of LEDs
ENERGY STAR® Requirements for the Use of LM-80 Data (This standard was not accredited by IAS)

1.3 Testing Equipment

Device	Manufacture	Model No	Serial No	Calibration date	Calibration due date
0.3m integrating sphere	EVERFINE	Diameter 0.3m	1011119	2020-03-08	2021-03-07
Programmable Test Power for LEDs	EVERFINE	LED300E	1008002	2020-03-08	2021-03-07
High accuracy array spectroradiometer	EVERFINE	HAAS-2000	1012016T	2020-03-08	2021-03-07
Standard Light Source	EVERFINE	D204	G100283CA8351158	2019-11-19	2020-11-18
Precision digital stabilized DC power supply	EVERFINE	WY605-V110	G115987CJ7321114	2020-03-16	2021-03-15
Multilayer aging machine	BACL	B2-270	20015	2020-03-11	2021-03-10
DC Power Supply	BACL	B12001-12	90023	2020-03-16	2021-03-15

1.4 Drive Level

Samples are driven with a constant direct current (DC) during maintenance test, photometric and electrical measurement. The current value was regulated to within $\pm 3\%$ of the specified value of the manufacturer during maintenance test, and was within $\pm 0.5\%$ during photometric and electrical measurement test.

1.5 Ambient Conditions for Maintenance Test

For lumen maintenance test, samples within one data set, were installed on cooling boards in thermal chambers with minimal ambient airflow. The case temperature and ambient temperature was monitored by thermocouples which one was soldered to the LED location, while the other is mounted at a distance of 5 mm above the TMP location.

During life testing, TMP_{LED} of the coldest LEDs were maintained at a temperature that was greater than or equal to $2^{\circ}C$ below the corresponding nominal case temperature. Surrounding air was maintained at a temperature that was greater than or equal to $5^{\circ}C$ below the corresponding nominal case temperature. Thermocouples were shielded from direct DUT optical radiation and comply with

Samples were connected to DC power supply in series circuits with a constant current. The forward current was regulated to within $\pm 3\%$ of the specified value of the manufacturer.

The relative humidity within chamber was kept less than 65% during test.

For photometry measurement, the ambient temperature during test was set to $25^{\circ}C \pm 2^{\circ}C$, RH <65%.

1.6 Photometric Measurement Method and Uncertainty

Integrating sphere and spectroradiometer is used to measure luminous flux and chromaticity coordinate u_v . 2° measurement was used and sample was driven by DC power supply. The forward current was regulated to within $\pm 0.5\%$ of the nominal value. The test system was calibrated by halogen reference lamp. The ambient temperature during test was set to $25^{\circ}C \pm 2^{\circ}C$, RH <65%. The temperature measurement point was located in the sphere and the temperature was detected by a temperature probe.

The uncertainty of the light output measurements is $U=1.59\%$ ($K=2$), at the 95% confidence level. The uncertainty of the correlated color temperature measurements is $U=21K$ ($K=2$), at the 95% confidence level.

The uncertainty of the temperature is $U=0.8671^{\circ}C$ ($K=2$), at the 95% confidence level.

1.7 Statement of Traceability

Bay Area Compliance Laboratories Corp. (Dongguan) attested that all calibration has been performed using suitable standards traceable to National Primary Standards and International System of Units (SI).

1.8 Sample Set

Data Set 1: $85^{\circ}C$, 100mA

Part Number: HL-AS-3528HW-3C-S1-08L-PCT-HR5
Number of Units: 30
Case Temperature: $>83^{\circ}C$
Ambient Temperature: $>80^{\circ}C$
Life Test Drive Current: 100mA
Measurement Current: 100mA

Data Set 2: $105^{\circ}C$, 100mA

Part Number: HL-AS-3528HW-3C-S1-08L-PCT-HR5
Number of Units: 30
Case Temperature: $>103^{\circ}C$
Ambient Temperature: $>100^{\circ}C$
Life Test Drive Current: 100mA
Measurement Current: 100mA



2 - Summary of Test Result

FINAL

3 - Test Data

3.1 Data Set 1, 85°C, 100mA (Lumen Maintenance)

No.	Lumen Maintenance (%)						
	0hr(Initial)	1000hrs	2000hrs	3000hrs	4000hrs	5000hrs	6000hrs
1	107.10	100.09	99.81	99.63	99.35	99.25	98.97
2	106.90	100.28	100.09	99.81	99.53	99.35	99.16
3	106.30	100.09	99.81	99.62	99.25	99.15	98.97
4	103.00	100.10	99.81	99.61	99.42	99.13	98.64
5	107.10	100.09	99.91	99.63	99.16	98.97	98.79
6	108.60	100.09	99.82	99.54	99.26	99.08	98.99
7	108.20	100.09	99.72	99.45	99.08	98.71	98.52
8	108.50	100.18	99.82	99.63	99.35	98.71	98.43
9	107.90	100.09	99.91	99.63	99.35	99.17	98.89
10	108.50	99.82	99.63	99.26	98.99	98.71	98.53
11	106.60	99.91	99.62	99.25	98.97	98.50	98.22
12	105.20	100.10	99.81	99.52	99.43	98.95	98.67
13	107.60	100.09	99.81	99.44	99.07	98.88	98.51
14	106.10	100.19	99.91	99.53	99.25	98.96	98.87
15	102.90	99.81	99.61	99.51	99.13	98.74	98.54
16	107.50	100.09	99.91	99.72	99.44	99.16	98.88
17	105.60	99.91	99.62	99.34	98.96	98.77	98.30
18	107.60	100.09	99.81	99.54	99.26	98.79	98.42
19	108.00	100.19	99.91	99.63	99.17	98.89	98.70
20	105.30	99.81	99.53	99.34	99.15	98.86	98.58
21	107.90	100.19	99.91	99.63	99.26	99.07	98.98
22	104.80	100.10	99.71	99.52	99.33	98.76	98.47
23	106.50	100.09	99.81	99.34	98.97	98.69	98.31
24	101.90	100.10	99.90	99.51	99.21	98.72	98.43
25	106.30	100.09	99.91	99.62	99.25	98.78	98.59
26	105.70	100.19	99.81	99.53	99.24	98.86	98.68
27	107.30	100.09	99.91	99.44	99.07	98.97	98.88
28	106.50	100.09	99.91	99.53	99.34	99.15	98.78
29	106.90	100.09	99.81	99.44	99.06	98.97	98.60
30	106.30	100.28	99.91	99.62	99.25	99.06	98.78
Avg.	106.49	100.08	99.81	99.53	99.22	98.93	98.67
Med.	106.75	100.09	99.81	99.53	99.25	98.92	98.65
st dev	1.67	0.12	0.12	0.13	0.15	0.20	0.24
Min.	101.90	99.81	99.53	99.25	98.96	98.50	98.22
Max.	108.60	100.28	100.09	99.81	99.53	99.35	99.16

3.2 Data Set 1, 85°C, 100mA (Forward Voltage)

No.	Forward Voltage (V)						
	0hr(Initial)	1000hrs	2000hrs	3000hrs	4000hrs	5000hrs	6000hrs
1	9.119	9.121	9.121	9.131	9.128	9.124	9.124
2	9.184	9.185	9.192	9.199	9.184	9.187	9.190
3	9.083	9.078	9.090	9.093	9.129	9.091	9.085
4	9.079	9.078	9.086	9.091	9.127	9.092	9.090
5	9.088	9.086	9.092	9.100	9.132	9.095	9.098
6	9.061	9.060	9.069	9.081	9.110	9.116	9.114
7	9.152	9.152	9.158	9.166	9.141	9.142	9.141
8	9.158	9.153	9.162	9.172	9.155	9.152	9.159
9	9.129	9.136	9.138	9.146	9.148	9.131	9.142
10	9.092	9.097	9.103	9.106	9.104	9.103	9.104
11	9.086	9.087	9.096	9.102	9.104	9.095	9.107
12	9.085	9.086	9.093	9.103	9.113	9.109	9.101
13	9.124	9.126	9.138	9.144	9.127	9.127	9.137
14	9.132	9.126	9.124	9.125	9.124	9.135	9.126
15	9.067	9.070	9.080	9.088	9.123	9.087	9.099
16	9.188	9.187	9.195	9.206	9.184	9.184	9.185
17	9.116	9.123	9.125	9.131	9.170	9.123	9.126
18	9.074	9.078	9.087	9.087	9.131	9.093	9.082
19	9.107	9.109	9.127	9.116	9.119	9.124	9.123
20	9.084	9.086	9.097	9.100	9.106	9.093	9.095
21	9.074	9.079	9.086	9.085	9.119	9.085	9.059
22	9.092	9.089	9.106	9.109	9.103	9.117	9.087
23	9.134	9.133	9.146	9.149	9.121	9.135	9.144
24	9.073	9.067	9.085	9.086	9.081	9.082	9.081
25	9.093	9.091	9.107	9.107	9.102	9.102	9.101
26	9.087	9.088	9.096	9.113	9.108	9.097	9.106
27	9.073	9.070	9.083	9.093	9.114	9.107	9.101
28	9.109	9.106	9.113	9.131	9.135	9.127	9.139
29	9.105	9.101	9.115	9.129	9.125	9.127	9.127
30	9.133	9.132	9.145	9.156	9.153	9.135	9.126
Avg.	9.106	9.106	9.115	9.122	9.127	9.117	9.117
Med.	9.093	9.094	9.107	9.111	9.125	9.117	9.111
st dev	0.034	0.034	0.032	0.033	0.024	0.027	0.030
Min.	9.061	9.060	9.069	9.081	9.081	9.082	9.059
Max.	9.188	9.187	9.195	9.206	9.184	9.187	9.190

3.3 Data Set 1, 85°C, 100mA (Chromaticity Shift)

No.			CCT(K)						
	Ohr(Initial)			1000hrs	2000hrs	3000hrs	4000hrs	5000hrs	6000hrs
1	0.2562	0.5306	2819	0.0003	0.0005	0.0006	0.0009	0.0011	0.0012
2	0.2575	0.5315	2787	0.0001	0.0004	0.0007	0.0009	0.0009	0.0011
3	0.2599	0.5304	2742	0.0002	0.0005	0.0006	0.0009	0.0012	0.0012
4	0.2580	0.5311	2778	0.0001	0.0004	0.0007	0.0010	0.0008	0.0011
5	0.2583	0.5313	2771	0.0004	0.0006	0.0008	0.0010	0.0007	0.0010
6	0.2572	0.5297	2802	0.0003	0.0006	0.0010	0.0012	0.0011	0.0011
7	0.2581	0.5316	2775	0.0002	0.0005	0.0007	0.0010	0.0011	0.0014
8	0.2584	0.5328	2763	0.0004	0.0006	0.0009	0.0010	0.0012	0.0012
9	0.2582	0.5321	2770	0.0003	0.0006	0.0009	0.0012	0.0011	0.0012
10	0.2589	0.5305	2763	0.0003	0.0005	0.0007	0.0009	0.0009	0.0011
11	0.2600	0.5299	2742	0.0002	0.0004	0.0006	0.0008	0.0008	0.0009
12	0.2634	0.5321	2663	0.0003	0.0006	0.0007	0.0010	0.0012	0.0013
13	0.2576	0.5283	2799	0.0003	0.0006	0.0009	0.0012	0.0009	0.0011
14	0.2597	0.5320	2739	0.0002	0.0004	0.0007	0.0009	0.0011	0.0012
15	0.2581	0.5307	2778	0.0002	0.0003	0.0005	0.0008	0.0008	0.0010
16	0.2579	0.5321	2777	0.0001	0.0004	0.0006	0.0009	0.0005	0.0008
17	0.2583	0.5307	2773	0.0002	0.0005	0.0008	0.0010	0.0011	0.0011
18	0.2618	0.5310	2700	0.0001	0.0004	0.0006	0.0009	0.0014	0.0014
19	0.2581	0.5313	2775	0.0001	0.0003	0.0006	0.0008	0.0009	0.0012
20	0.2618	0.5311	2699	0.0004	0.0005	0.0006	0.0009	0.0008	0.0011
21	0.2589	0.5315	2758	0.0003	0.0005	0.0006	0.0007	0.0007	0.0010
22	0.2591	0.5284	2768	0.0004	0.0005	0.0008	0.0010	0.0006	0.0006
23	0.2612	0.5313	2710	0.0003	0.0006	0.0009	0.0012	0.0008	0.0010
24	0.2591	0.5326	2749	0.0002	0.0005	0.0007	0.0008	0.0007	0.0009
25	0.2620	0.5325	2691	0.0003	0.0005	0.0007	0.0010	0.0009	0.0009
26	0.2608	0.5315	2719	0.0001	0.0003	0.0005	0.0007	0.0013	0.0013
27	0.2610	0.5329	2708	0.0001	0.0003	0.0004	0.0006	0.0015	0.0016
28	0.2614	0.5313	2706	0.0001	0.0002	0.0006	0.0008	0.0014	0.0015
29	0.2595	0.5334	2738	0.0004	0.0005	0.0007	0.0009	0.0011	0.0013
30	0.2610	0.5307	2717	0.0002	0.0005	0.0008	0.0010	0.0014	0.0015
Avg.	0.2594	0.5312	2749	0.0003	0.0005	0.0007	0.0009	0.0010	0.0011
Med.	0.2590	0.5313	2761	0.0002	0.0005	0.0007	0.0009	0.0010	0.0011
st dev	0.0017	0.0012	37	0.0001	0.0001	0.0001	0.0001	0.0003	0.0002
Min.	0.2562	0.5283	2663	0.0001	0.0002	0.0004	0.0006	0.0005	0.0006
Max.	0.2634	0.5334	2819	0.0004	0.0006	0.0010	0.0012	0.0015	0.0016

3.4 Data Set 2, 105°C, 100mA (Lumen Maintenance)

No.	Lumen Maintenance (%)						
	Ohr(Initial)	1000hrs	2000hrs	3000hrs	4000hrs	5000hrs	6000hrs
31	109.20	99.82	99.54	99.18	98.81	98.35	97.99
32	106.30	99.91	99.53	99.25	98.97	98.49	98.02
33	109.00	99.82	99.45	98.99	98.62	98.26	98.07
34	107.20	99.91	99.63	99.35	98.97	98.79	98.69
35	107.90	100.09	99.72	99.35	98.98	98.52	98.15
36	106.10	99.81	99.43	99.06	98.77	98.30	97.93
37	106.20	99.72	99.34	99.06	98.78	98.31	97.93
38	108.20	100.09	99.91	99.54	99.26	99.08	98.89
39	107.30	99.81	99.63	99.44	98.97	98.79	98.60
40	101.70	99.90	99.61	99.21	98.92	98.62	98.33
41	107.80	100.09	99.63	99.17	98.79	98.42	98.24
42	101.20	99.90	99.51	99.11	98.81	98.67	98.55
43	107.90	99.91	99.54	99.26	98.80	98.33	97.96
44	108.80	99.82	99.54	99.17	98.90	98.71	98.35
45	107.40	100.09	99.81	99.53	99.16	98.70	98.42
46	107.60	99.91	99.54	99.07	98.79	98.42	98.23
47	107.70	99.81	99.44	99.16	98.79	98.14	97.96
48	106.10	99.91	99.53	99.25	98.87	98.68	98.40
49	103.10	99.81	99.42	98.93	98.45	98.25	97.77
50	106.20	99.91	99.62	99.25	98.96	98.40	97.93
51	106.70	100.19	99.81	99.53	99.06	98.97	98.50
52	106.20	99.81	99.53	99.15	98.78	98.49	98.21
53	102.50	99.80	99.51	99.12	98.73	98.54	98.05
54	106.10	100.19	99.91	99.62	99.15	98.68	98.21
55	105.80	99.91	99.53	99.24	98.87	98.39	98.20
56	107.60	100.09	99.91	99.44	98.98	98.70	98.42
57	105.90	100.09	99.72	99.24	98.77	98.58	98.39
58	107.40	99.81	99.44	99.07	98.70	98.23	98.04
59	100.90	99.80	99.41	98.95	98.54	98.05	97.57
60	106.30	99.81	99.53	99.25	98.87	98.31	97.84
Avg.	106.28	99.92	99.59	99.23	98.86	98.51	98.19
Med.	106.50	99.90	99.54	99.23	98.84	98.49	98.21
st dev	2.23	0.13	0.15	0.18	0.17	0.24	0.29

3.5 Data Set 2, 105°C, 100mA (Forward Voltage)

No.	Forward Voltage (V)						
	0hr(Initial)	1000hrs	2000hrs	3000hrs	4000hrs	5000hrs	6000hrs
31	9.126	9.128	9.146	9.155	9.185	9.129	9.134
32	9.121	9.123	9.135	9.138	9.123	9.121	9.122
33	9.062	9.063	9.076	9.087	9.106	9.087	9.106
34	9.109	9.113	9.116	9.115	9.117	9.117	9.123
35	9.073	9.069	9.083	9.092	9.106	9.087	9.105
36	9.101	9.099	9.110	9.124	9.142	9.106	9.091
37	9.078	9.070	9.081	9.090	9.109	9.115	9.119
38	9.103	9.101	9.109	9.122	9.113	9.107	9.106
39	9.065	9.063	9.076	9.088	9.096	9.082	9.091
40	9.065	9.074	9.078	9.089	9.105	9.088	9.074
41	9.070	9.070	9.084	9.086	9.103	9.107	9.108
42	9.064	9.058	9.077	9.080	9.096	9.088	9.090
43	9.130	9.128	9.142	9.139	9.126	9.121	9.126
44	9.061	9.054	9.074	9.067	9.102	9.078	9.088
45	9.107	9.108	9.114	9.125	9.145	9.107	9.124
46	9.135	9.145	9.151	9.159	9.179	9.158	9.164
47	9.090	9.095	9.105	9.109	9.108	9.103	9.104
48	9.088	9.088	9.106	9.105	9.107	9.106	9.095
49	9.095	9.096	9.107	9.115	9.105	9.102	9.088
50	9.195	9.187	9.192	9.196	9.195	9.196	9.183
51	9.091	9.086	9.110	9.106	9.106	9.107	9.118
52	9.091	9.093	9.109	9.103	9.107	9.109	9.092
53	9.079	9.081	9.103	9.103	9.101	9.093	9.102
54	9.084	9.086	9.100	9.109	9.092	9.099	9.102
55	9.071	9.072	9.082	9.089	9.112	9.081	9.101
56	9.090	9.090	9.106	9.106	9.130	9.092	9.105
57	9.102	9.109	9.115	9.115	9.108	9.107	9.118
58	9.071	9.081	9.088	9.092	9.115	9.095	9.098
59	9.088	9.092	9.103	9.111	9.093	9.092	9.102
60	9.111	9.112	9.128	9.136	9.114	9.118	9.125
Avg.	9.094	9.094	9.107	9.112	9.118	9.107	9.110
Med.	9.090	9.091	9.106	9.108	9.108	9.106	9.105
st dev	0.028	0.029	0.027	0.027	0.026	0.024	0.022
Min.	9.061	9.054	9.074	9.067	9.092	9.078	9.074
Max.	9.195	9.187	9.192	9.196	9.195	9.196	9.183

3.6 Data Set 2, 105°C, 100mA (Chromaticity Shift)

No.	0hr(Initial)		CCT(K)	1000hrs	2000hrs	3000hrs	4000hrs	5000hrs	6000hrs
	31	0.2574	0.5308	2794	0.0004	0.0007	0.0009	0.0011	0.0013
32	0.2620	0.5298	2700	0.0002	0.0005	0.0007	0.0010	0.0011	0.0013
33	0.257Q	c							

FINAL

4 - DUT Photo

4.1 #Mechanical Dimensions

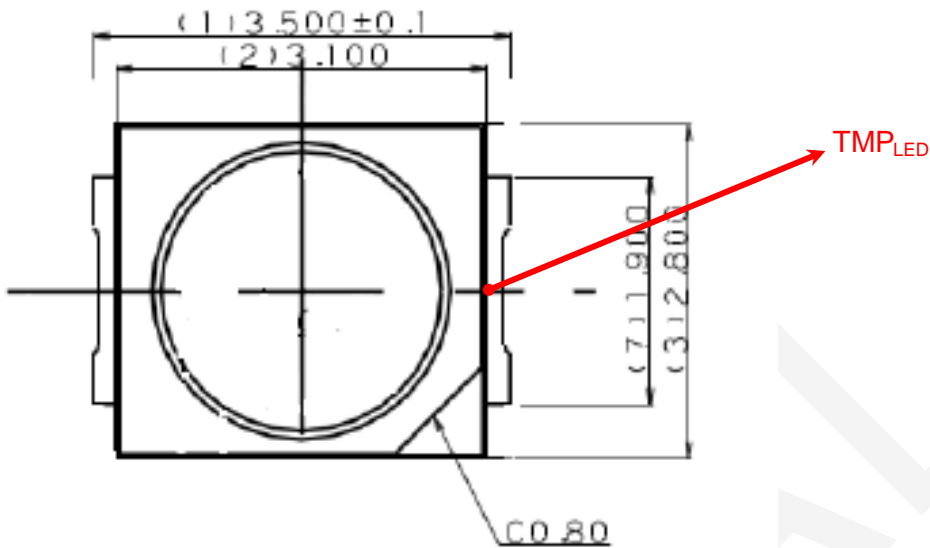

All dimensions are in millimeter

4.2 DUT Photo

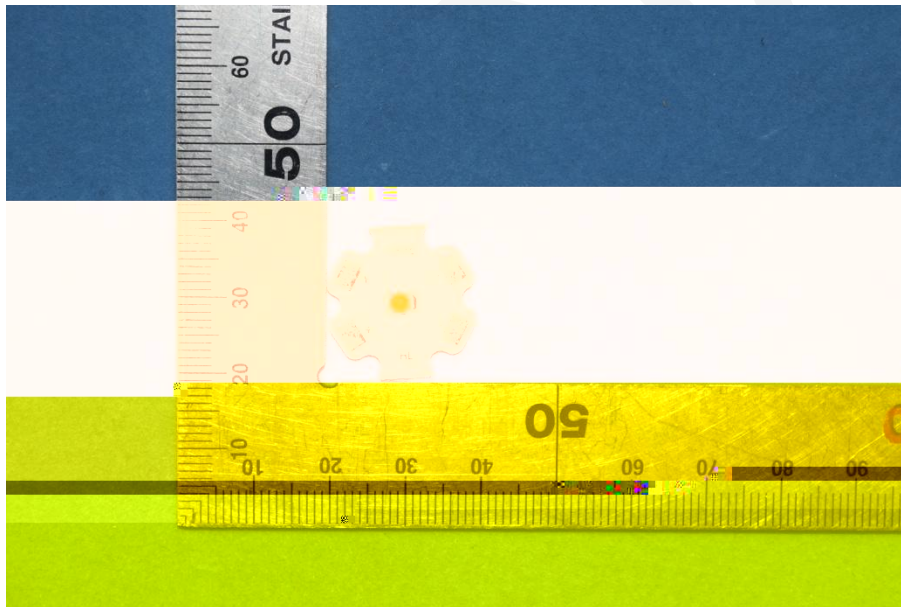

Directions

*****END OF REPORT*****

FINAL