

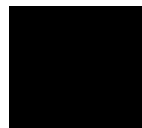

HONGLITRONIC  
鸿利光电



林德顺









# HL-AF-5060H415W-3-S1-TL-HR3

## Typical optical characteristics curves 典型光学特性曲线

正向电流与正向电压特性曲线

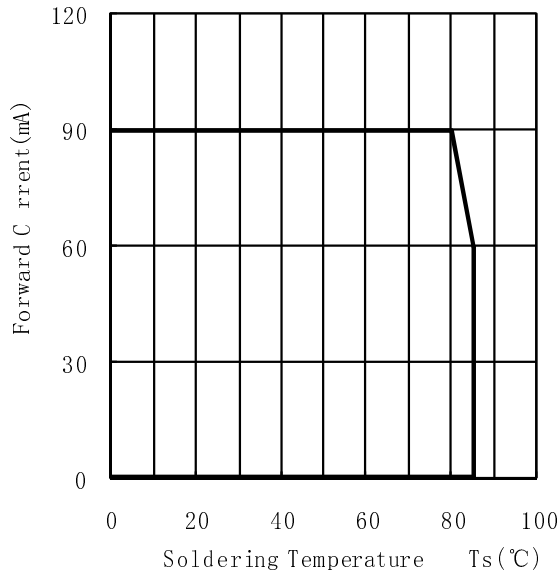

正向电流与相对光强特性曲线

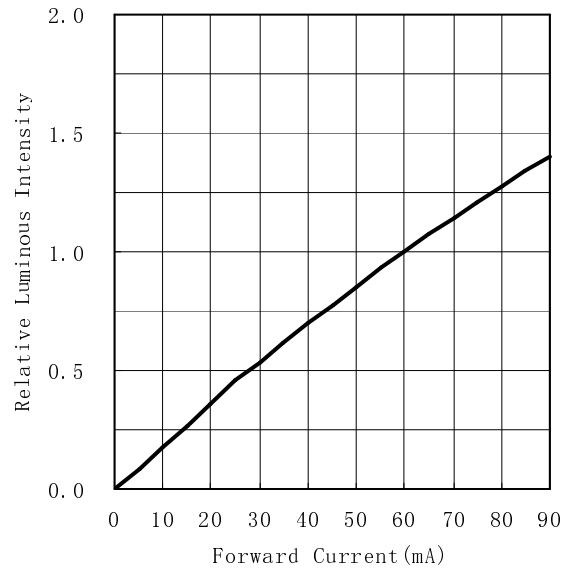

正向电压与正向电流特性曲线

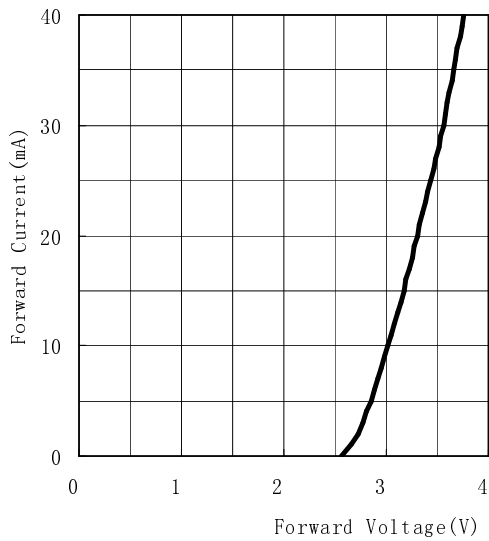

环境温度与相对光强特性曲线

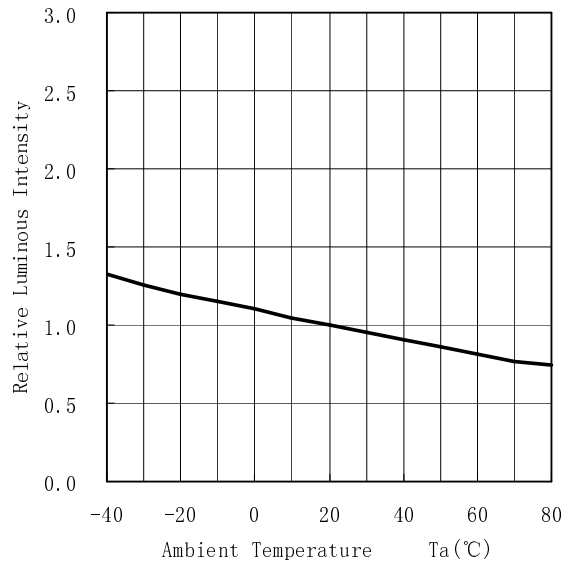

# HL-AF-5060H415W-3-S1-TL-HR3

## Typical optical characteristics curves 典型光学特性曲线

相对光谱分布特性曲线

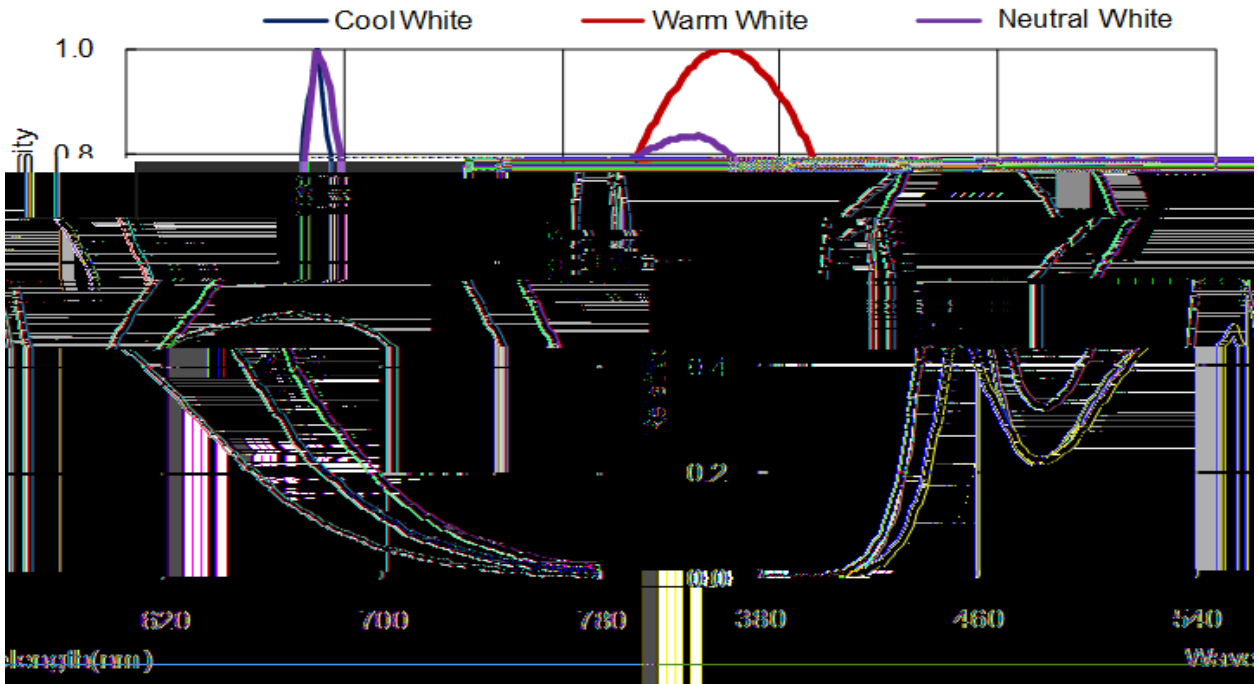

辐射图特性曲线

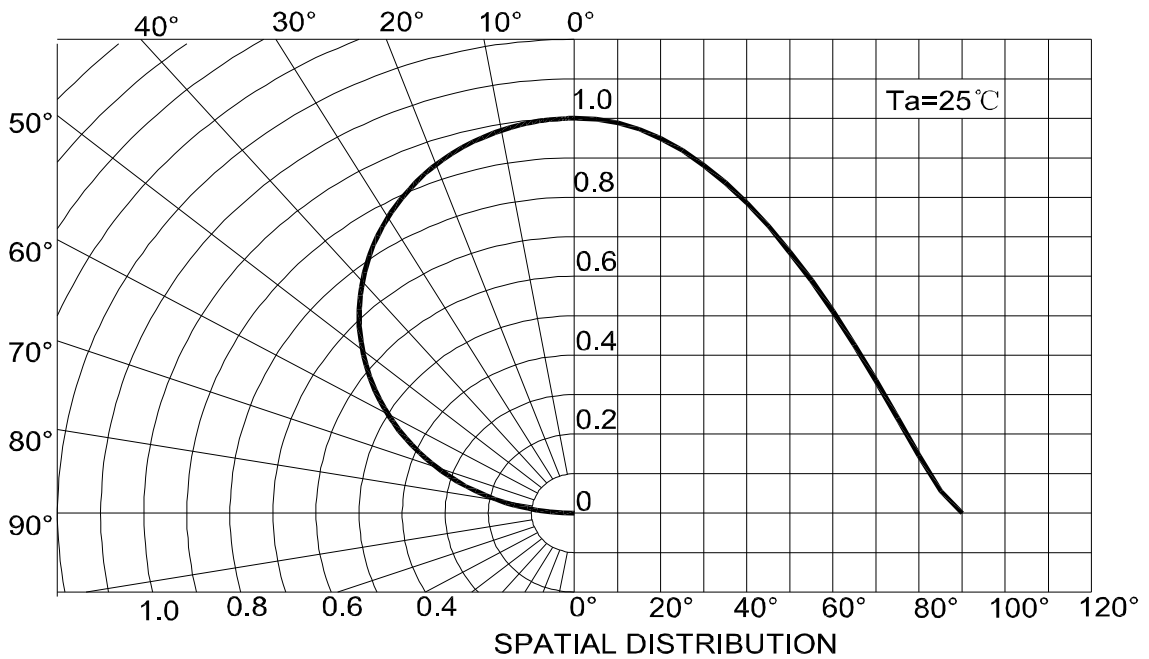



HONCLITRONIC  
鸿利光电

HL-AF-5060H415W-3

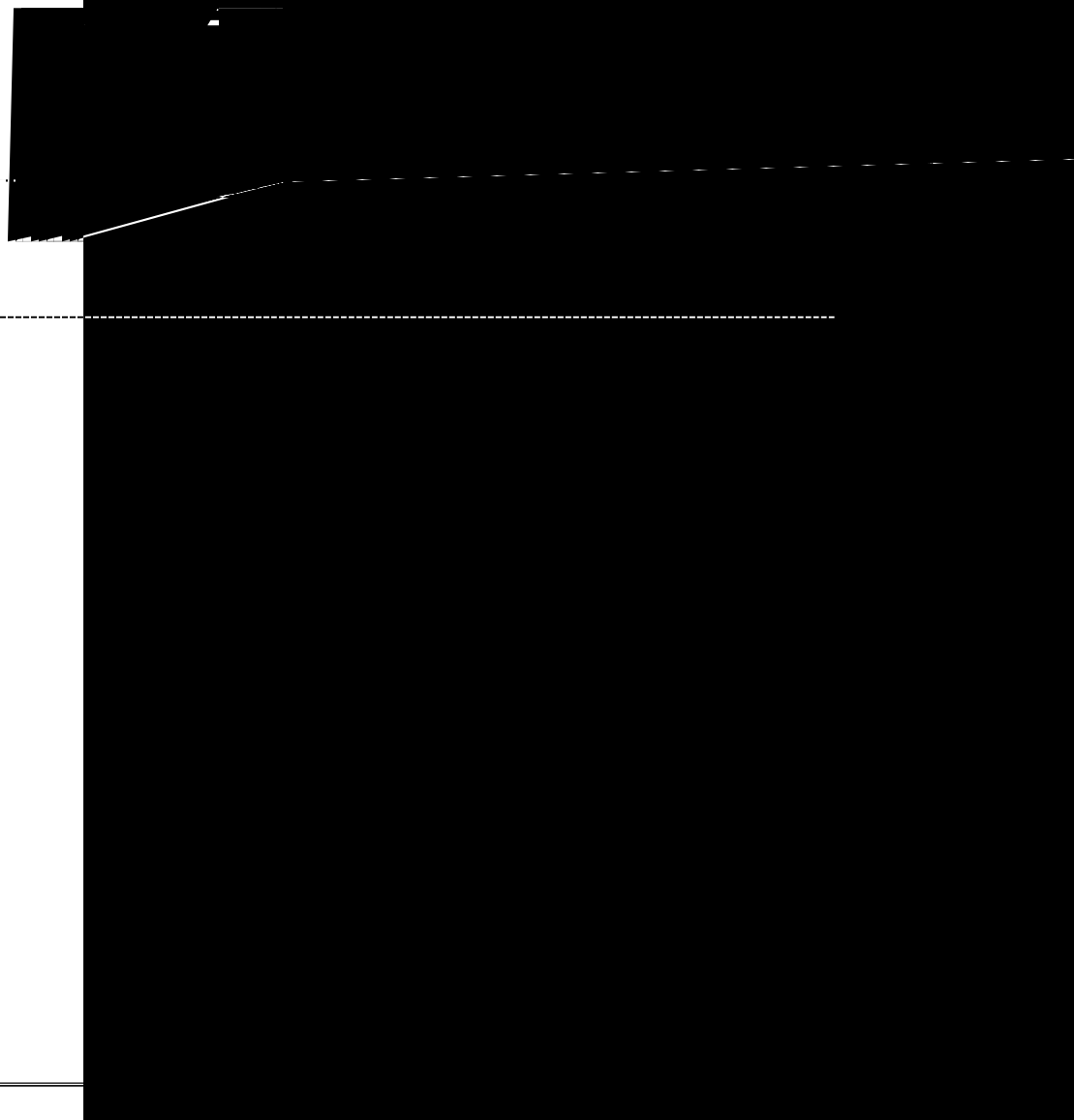



# HL-AF-5060H415W-3-S1-TL-HR3

## Bin 3 in Range of Chromaticity Coordinate Bin 区分类及色坐标范围

色温	代码	色温	代码
	0.3205	0.3481	0.3211
	0.3117	0.3393	0.3294
	0.3131	0.329	0.3296
	0.3213	0.3371	0.3219
	0.3213	0.3371	0.3219
	0.3131	0.329	0.3296
	0.3145	0.3187	0.3298
	0.3221	0.3261	0.3227
	0.3376	0.3616	0.3461
	0.3461	0.3685	0.3545
	0.3451	0.3561	0.3530
	0.3372	0.3497	0.3451
	0.3372	0.3497	0.3451
	0.3451	0.3561	0.3530
	0.3441	0.3437	0.3514
	0.3368	0.3378	0.3441
	0.3731	0.3853	0.3839
	0.3839	0.3920	0.3947
	0.3803	0.3777	0.3903
	0.3703	0.3716	0.3803
	0.3703	0.3716	0.3803
	0.3803	0.3777	0.3903
	0.3767	0.3634	0.3858
	0.3675	0.3578	0.3767





色温	代码			代码	
	0.4354	0.4142		0.4316	0.4059
	0.4430	0.4165		0.4390	0.4082
	0.4390	0.4082		0.4350	0.3998
	0.4316	0.4059		0.4279	0.3975



## HL-AF-5060H415W-3-S1-TL-HR3

### Reliability Test Items and Conditions 信赖性测试项目及条件

项目	参考标准	测试条件	时间	数量	接收/拒收
回流焊		℃			
温度循环		℃ ℃ ℃ ℃			
高温保存		℃ ℃			
低温保存		℃ ℃			
常温通电		℃ ℃			
高温高湿通电		℃ ℃			

### Failure Criteria

项目	符号	测试条件	判定标准	
			最小	最大
正向电压				
反向电流				
光通量				

...

规格上限

...

规格下限

\*

数据工作表中所示的技术信息仅限于典型特征和电路实例引用的产品. 它既不构成工业特性的保证, 也不构成任何许可的授权

## HL-AF-5060H415W-3-S1-TL-HR3

### Soldering Instructions (回流焊说明)

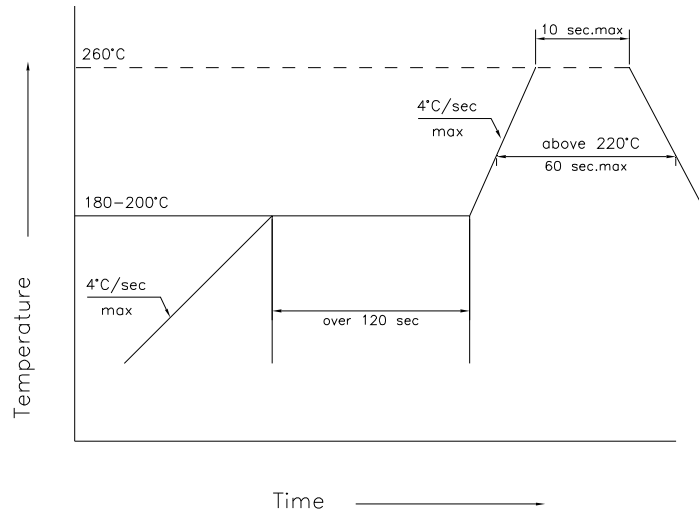

回流焊不可以做两次以上

当焊接时，不要在材料受热时用力压胶体表面

### Soldering iron 烙铁焊接

°C

当手工焊接时，烙铁的温度必须小于300°C，时间不可超过 3秒

手工焊接只可焊接一次

### Repairing 修补

LED回流焊后不应该修复，当修复是不可避免时，必须用双头烙铁（如下图），但必须事先确认这种方式会不会损坏LED本身的特性。

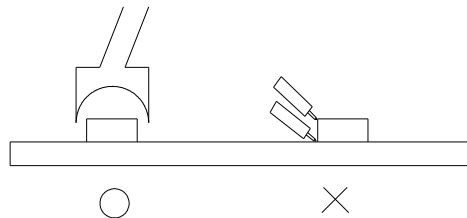

### \*Attention 注意事项

LED封装为硅胶，故LED胶体表面较软，用力按压胶体表面会影响LED可靠性，因此应有预防措施避免在封装的零件上的强大压力，当用吸嘴时，胶体表面的压力应是恰当的。





# HL-AF-5060H415W-3-S1-TL-HR3

La/e 标签

亮度等级  
电压等级  
色坐标  
色温

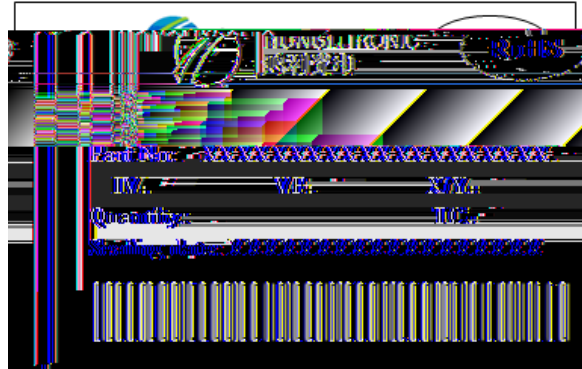

Tape Specifications 67 nits 8 mm9 载带规格 (单位: mm)

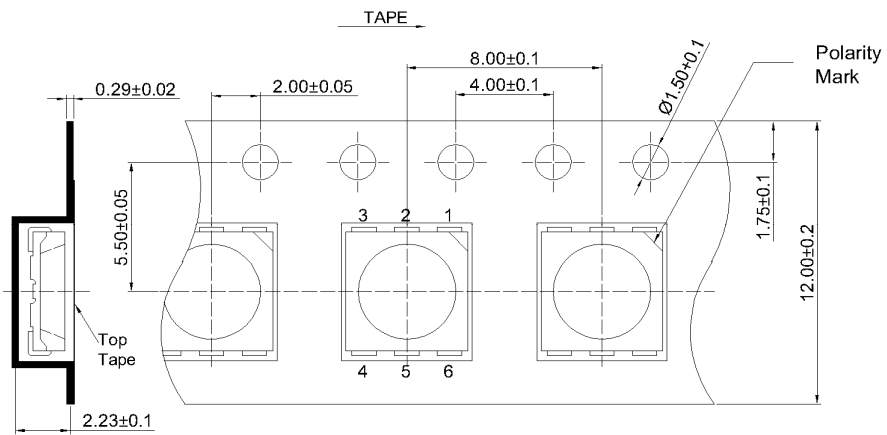

Reel Dimensions  
卷轴尺寸

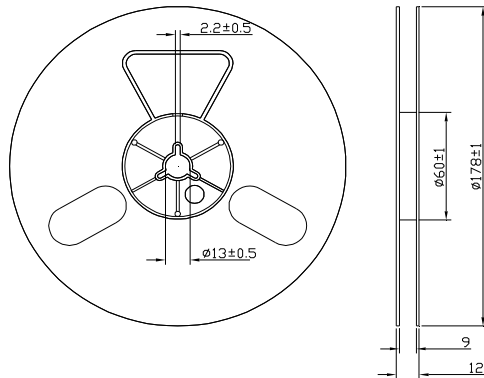

Moisture Resistant Packaging 防潮带包装

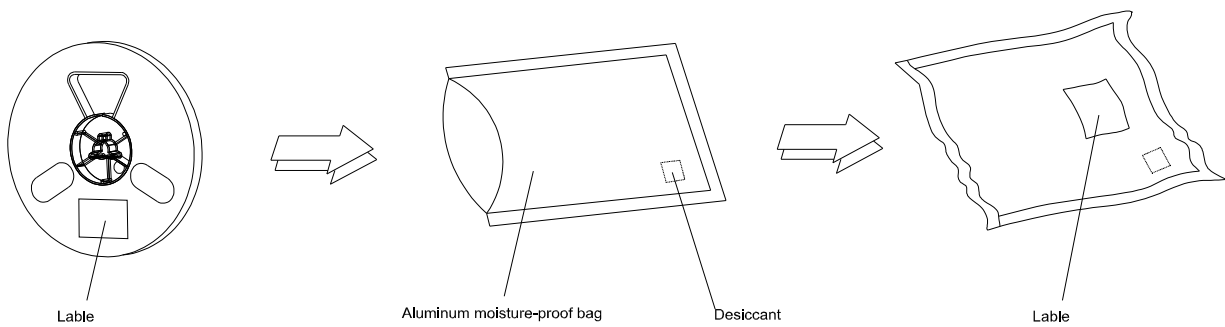

注: 标注公差为± 单位: